



Lobby Entrance Elevation



TOPSIDER  
BUILDING SYSTEMS  
*Commercial Portfolio*

## HOTEL COLLECTION UPPER MID-SCALE CONCEPT

### DESIGN OVERVIEW

Total Rooms 96  
Total Building Area 51,900 sf. or 4,822 m<sup>2</sup>  
Total Bldg Area per Room 540 sf or 50 m<sup>2</sup>

*Infinite Expansion & Amenity Possibilities  
Unlimited Exterior Architectural Styles*

### HOTEL AMENITIES

*128 Seat Restaurant & Bar  
180 Seat Ball Room  
2 - 60 Seat Conference Rooms  
Business Center  
Fitness Center  
Guest Services*

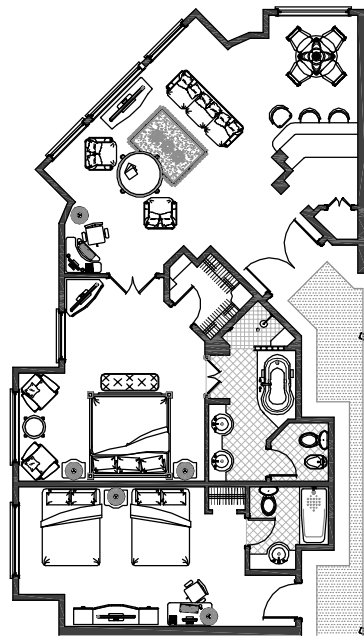

Grande Suite  
*Enlarged Plan*

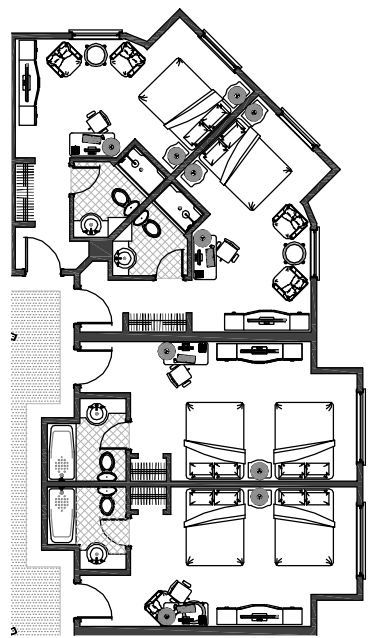

Double Queen/King  
*Enlarged Plan*

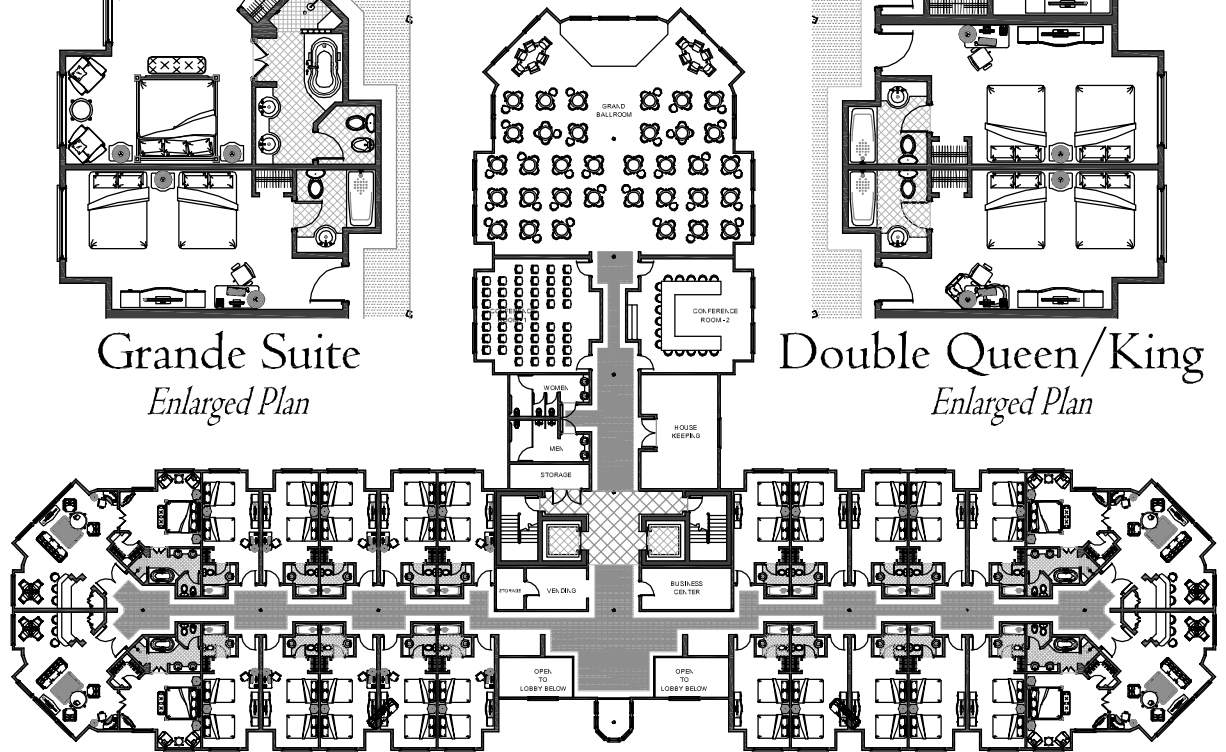

Level 3 Floor Plan

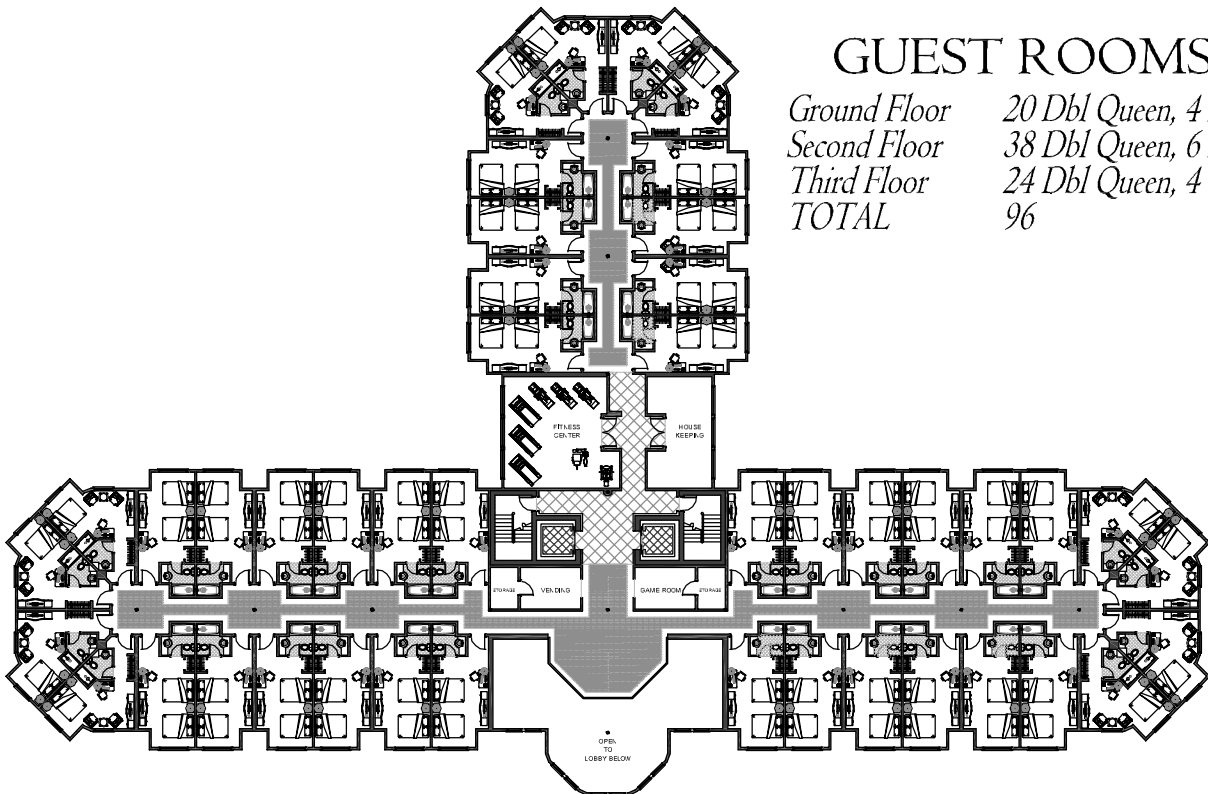

Level 2 Floor Plan

### GUEST ROOMS

Ground Floor	20 Dbl Queen, 4 King
Second Floor	38 Dbl Queen, 6 King
Third Floor	24 Dbl Queen, 4 Grand Suites
<b>TOTAL</b>	<b>96</b>

### SITE ANALYSIS

Building Foot Print	20,200 s.f. (20%)	1,876 m <sup>2</sup>
Hardscape	58,580 s.f. (58%)	5,442 m <sup>2</sup>
Softscape	22,220 s.f. (22%)	2,064 m <sup>2</sup>
<b>TOTAL</b>	<b>101,000 s.f. (100%)</b>	<b>9,383 m<sup>2</sup></b>

### PARKING ANALYSIS

96 Rooms	96 Spaces
21 Employees	21 Spaces
Restaurant	32 Spaces
<b>TOTAL</b>	<b>149 Spaces</b>

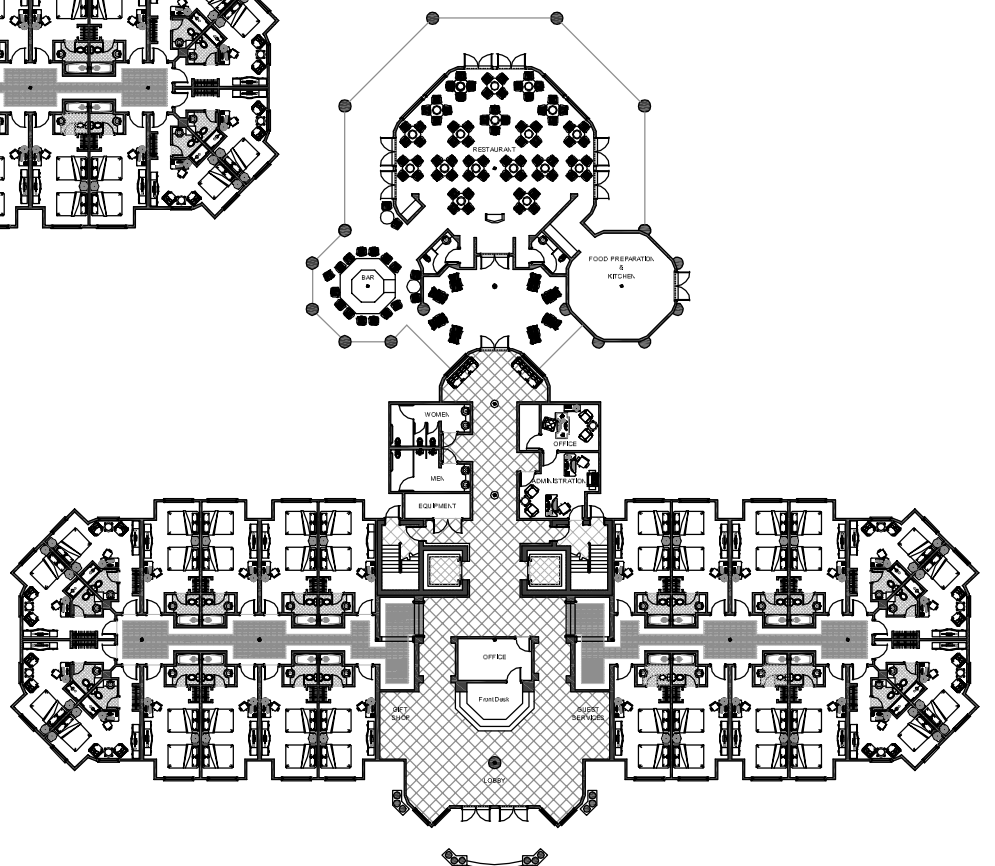
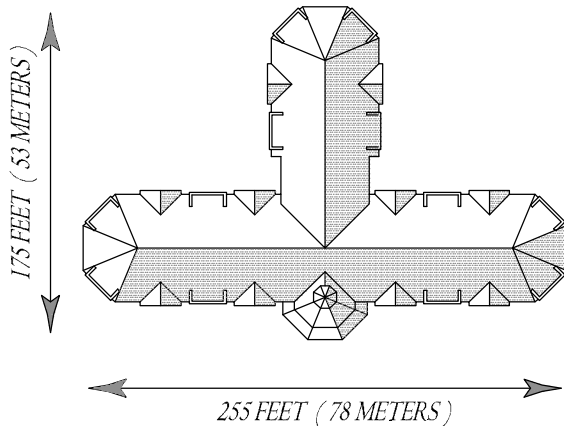

Lobby Level Floor Plan